

RADEX®-N Stahl-Lamellenkupplung

Standardbauarten

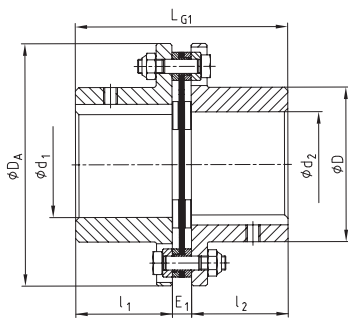

- Lagervorrätige Standardbauarten
- Einfach- und doppelkardanisch
- Wahlweise auch mit reibschlüssiger Welle-Nabe-Verbindung
- Fertigbohrung nach ISO-Passung H7, Passfedernute nach DIN 6885 Bl. 1 - JS9
- \odot -Schutz beurteilt und bestätigt nach EG-Richtlinie 94/9/EG



Bauart NN

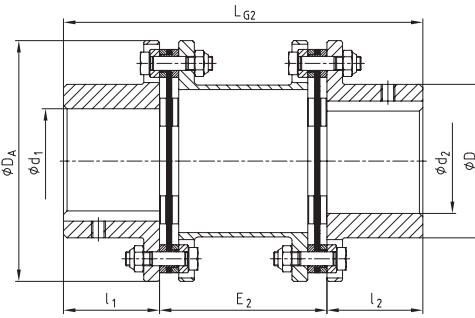

Bauart NANA 1

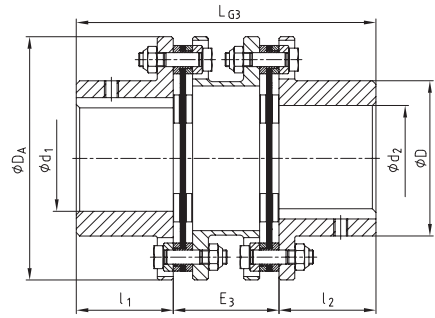

Bauart NANA 2

Größe	Fertigbohrung		Abmessungen [mm]																
	d ₁ /d ₂ max.	d ₃ /d ₄ max.	D	D ₁	D _A	l ₁ /l ₂	L _{G1}	E ₁	L _{G2}	E ₂	L _{G3}	E ₃	L _{G4}	E ₄	L _{G5}	E ₅	L _{G6}	E ₆	
20	20	–	32	–	56	20	45	5	100	60	–	–	–	–	–	–	–	–	–
25	25	–	40	–	68	25	56	6	110	60	–	–	–	–	–	–	–	–	–
35	35	–	54	–	82	40	86	6	150	70	–	–	–	–	–	–	–	–	–
38	38	–	58	–	94	45	98	8	170	80	–	–	–	–	–	–	–	–	–
42	42	–	68	–	104	45	100	10	170	80	–	–	–	–	–	–	–	–	–
50	50	–	78	–	126	55	121	11	206	96	–	–	–	–	–	–	–	–	–
60	60	55	88	77	138	55	121	11	206	96	170	60	160	50	114	4	124	14	–
70	70	65	102	90	156	65	141	11	246	116	200	70	190	60	134	4	144	14	–
80	80	75	117	104	179	75	164	14	286	136	233	83	220	70	154	4	167	17	–
85	85	80	123	112	191	80	175	15	300	140	246	86	232	72	164	4	178	18	–
90	90	85	132	119	210	80	175	15	300	140	251	91	233	73	166	6	184	24	–
105	105	90	147	128	225	90	200	20	340	160	281	101	263	83	186	6	204	24	–
115	115	100	163	145	265	100	223	23	370	170	309	109	288	88	206	6	227	27	–
135	135	115	184	160	305	135	297	27	520	250	–	–	–	–	–	–	–	–	–
160	160	130	213	180	340	160	354	34	620	300	–	–	–	–	–	–	–	–	–
180	180	140	242	190	390	180	374	34	660	300	–	–	–	–	–	–	–	–	–
190	190	170	265	230	440	190	420	40	680	300	–	–	–	–	–	–	–	–	–
220	220	185	305	250	495	220	480	40	740	300	–	–	–	–	–	–	–	–	–

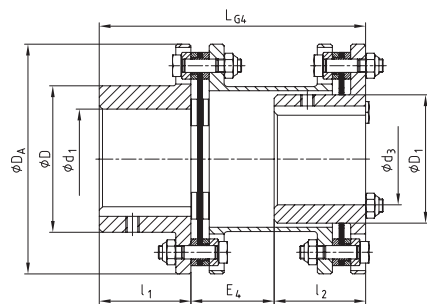

Bauart NENA 1

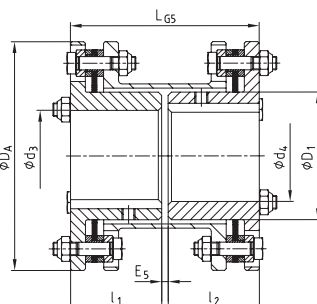

Bauart NENE 1

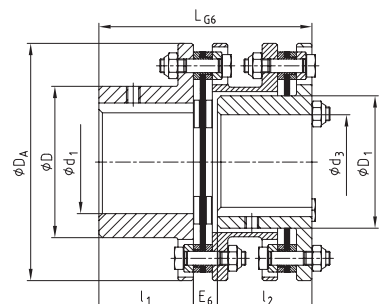

Bauart NENA 2

Bestellbeispiel:

RADEX®-N 60	NANA 1	Ø 50	Ø 60
Kupplungsgröße	Bauart	Bohrung d ₁	Bohrung d ₂