

ROTEX® Torsionally flexible couplings

Please order here:
as antriebstechnik + spannsysteme
 tel.: 0049 40 679467-0, fax: 0049 40 679467-20

Shaft coupling design No. 001 - material steel



- Hubs from steel, specifically suitable for drive elements subject to high loads, e. g. steel mills, elevator drives, spline hubs, etc.)
- Torsionally flexible, maintenance-free, vibration-damping
- Axial plug-in, fail-safe
- Allow machining - good dynamic properties
- Compact design/small flywheel effect
- Finish bore according to ISO fit H7, feather keyway according to DIN 6885 sheet 1 - JS9
- Basic programme/stock programme see pages 38 and 39
- Approved according to EC Standard 94/9/EC (Explosion Certificate ATEX 95)
- Mounting instructions available

Components

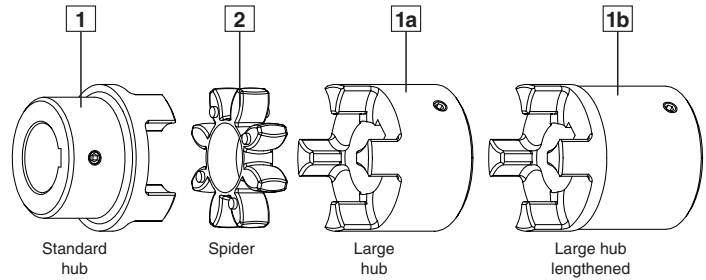
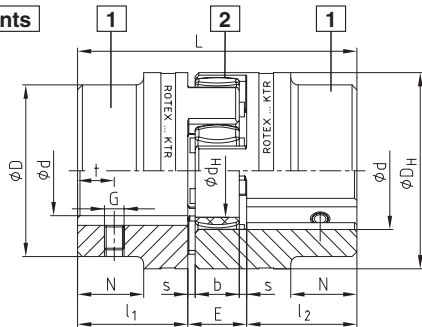

Steel (thread on the keyway)

ROTEX® steel																	
Size	Component	Spider (part 2) ¹⁾ Rated torque [Nm]			Finish bore d (min-max)	Dimensions [mm]											
		92 Sh A	98 Sh A	64 Sh D		General						Spec. for steel		Thread for setscrews			
					L	$l_1; l_2$	E	b	s	D_H	d_H	D	N	G	t	T_A [Nm]	
19	1a	10	17	21	0-25	66	25	16	12	2	40	18	40	-	M5	10	2
	1b					90	37										
24	1a	35	60	75	0-35	78	30	18	14	2	55	27	55	-	M5	10	2
	1b					118	50										
28	1a	95	160	200	0-40	90	35	20	15	2,5	65	30	65	-	M8	15	10
	1b					140	60										
38	1	190	325	405	0-48	114	45	24	18	3	80	38	70	27	M8	15	10
	1b					164	70						80	-			
42	1	265	450	560	0-55	126	50	26	20	3	95	46	85	28	M8	20	10
	1b					176	75						95	-			
48	1	310	525	655	0-62	140	56	28	21	3,5	105	51	95	32	M8	20	10
	1b					188	80						105	-			
55	1	410	685	825	0-74	160	65	30	22	4	120	60	110	37	M10	20	17
	1b					210	90						120	-			
65	1	625	940	1175	0-80	185	75	35	26	4,5	135	68	115	47	M10	20	17
	1b					235	100						135	-			
75	1	1280	1920	2400	0-95	210	85	40	30	5	160	80	135	53	M10	25	17
	1b					260	110						160	-			
90	1	2400	3600	4500	0-110	245	100	45	34	5,5	200	100	160	62	M12	30	40
	1b					295	125						200	-			

ROTEX® sintered steel																
Size	Component	Spider (part 2) ¹⁾ Rated torque [Nm]		Finish bore d	Dimensions [mm]											
		92 Sh A	98 Sh A		General						Thread for setscrews					
					L	$l_1; l_2$	E	b	s	D_H	d_H	D	N	G	t	T_A [Nm]
14	1a	7,5	12,5	unbored, 8, 10, 11, 12, 14	35	11	13	10	1,5	30	10	30	-	M4	5	1,5
19	1a	10	17	unbored, 14, 16, 19, 20, 22, 24	66	25	16	12	2	40	18	40	-	M5	10	2

▲ = If no material is mentioned in the order, the calculation/order is based on the material marked with

1) Maximum torque of the coupling T_{Kmax} = rated torque of the coupling T_{KNenn} x 2

ROTEX® 19 – 48 from stainless steel available from stock

- ROTEX® 19, 28 and 42 – hub material X10CrNiS 18-9 material number 1.4305 (V2A) DIN 17440

- ROTEX® 24, 38 and 48 – hub material X6CrNiMoTi17-12-2 material number 1.4571 (V4A) DIN 17440

Order form:

ROTEX®-38	St	92	1	–	Ø 45	1a	–	Ø 25
Coupling size	Material	Spider hardness Shore A]	Hub design		Finish bore	Hub design		Finish bore